

Needle roller bearings, with machined rings, with flanges, without an inner ring

Principal dimensions			Basic load ratings		Speed ratings	Limiting speed	Designation
F _w	D	C	dynamic C	static C ₀	Reference speed		
mm			kN		r/min		-
43	58	22	39,1	61	9000	10000	NKS 43

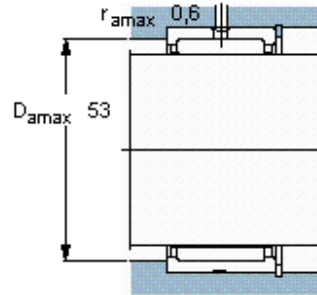
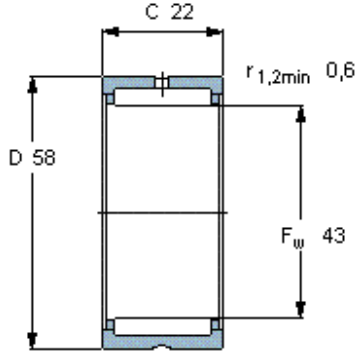

Appropriate seals

- G seal -
- SD seal -
- CR seal -